



Pattern Book

2026



Trail Class 700, 1, 2, 3, 4, 5, 6, 7, 8, 9, 10, 11, 12, 13, 14, 15, 16, 17, 18, 19, 20, 21, 22, 23, 24, 25, 26

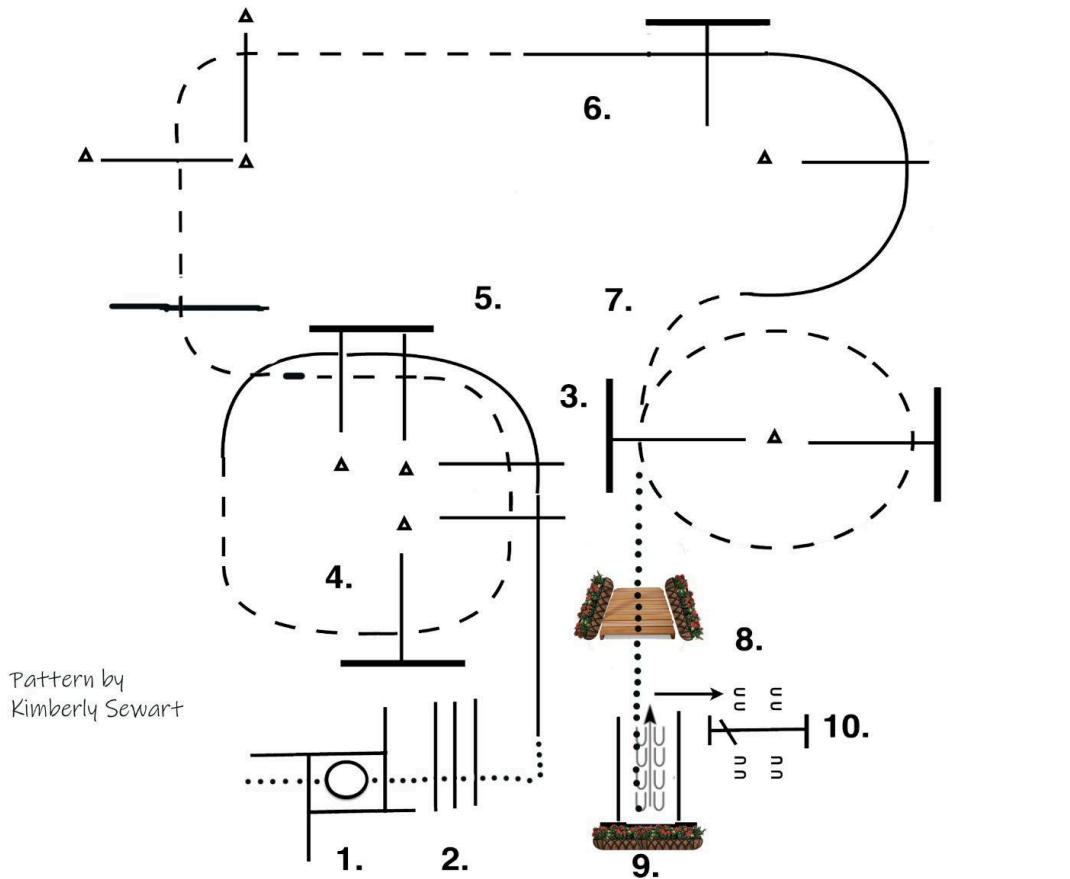

Pattern by Kimberly Sewart

1. Walk into box, hesitate. Then turn 360 either direction & walk out.
2. Walk over logs.
3. Left lead lope over 4 poles as shown, then jog.
4. Jog over 5 poles left as drawn.
5. Jog over 3 poles right as drawn.
6. Lope right lead over poles.
7. Jog over poles in a circle to the left as drawn, then walk.
8. Walk over bridge into chute.
9. Back out of chute to gate.
10. Work gate, left hand push.

| | |
|--------------|-------|
| Walk | |
| Jog | ----- |
| Extended Jog | ----- |
| Lope | ————— |
| Lead Change | |
| Back | |
| Marker | |



Trail Walk/Trot Class 27, 28, 29, 30, 31, 32, 33, 34, 35, 36 37, 38, 39, 40, 41

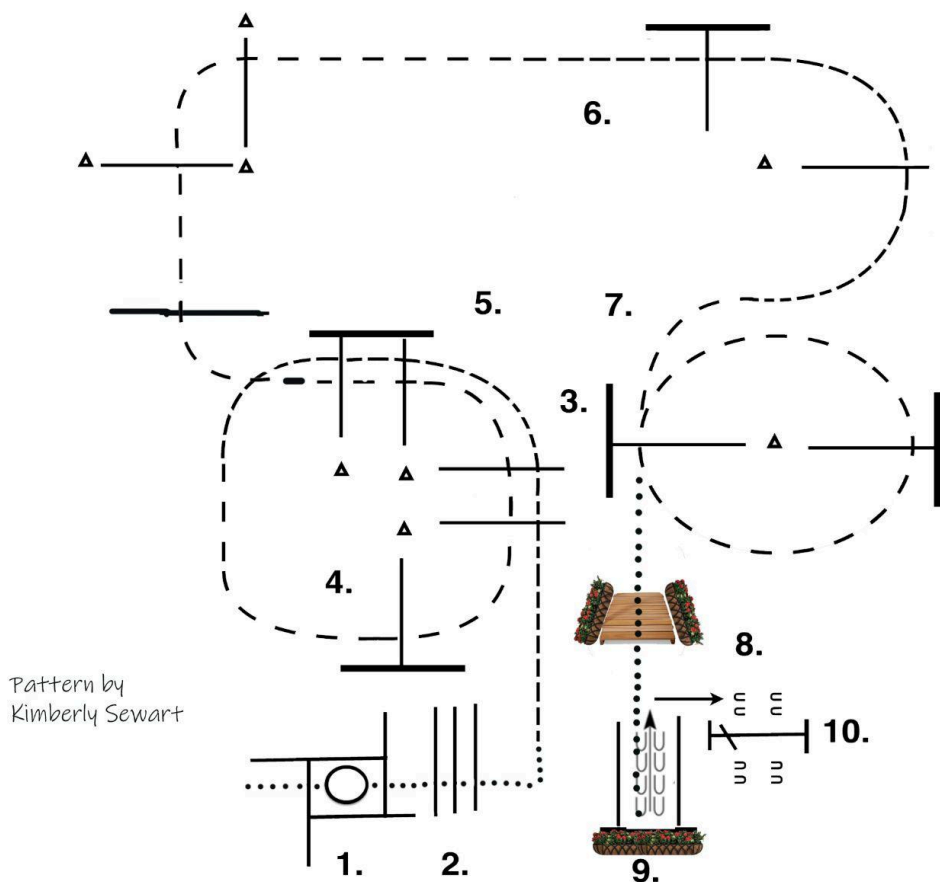

Pattern by Kimberly Sewart

1. Walk into box, hesitate. Then turn 360 either direction & walk out.
2. Walk over logs.
3. Jog over 4 poles as shown.
4. Jog over 5 poles left as drawn.
5. Jog over 3 poles right as drawn.
6. Continue jog over poles to the right as drawn..
7. Jog over poles in a circle to the left as drawn, then walk.
8. Walk over bridge into chute.
9. Back out of chute to gate.
10. Work gate, left hand push.

| | |
|--------------|--------|
| Walk | |
| Jog | ----- |
| Extended Jog | ----- |
| Lope | ————— |
| Lead Change | ↗↘ |
| Back | ← 3333 |
| Marker | ▲ |



Trail In Hand Class 43, 44, 45, 46, 47, 48, 49, 50, 51, 52, 53, 54
 Class 42 Lead Line & Walk - Whoa

****Lead Line & Walk - Whoa riders will WALK ONLY**

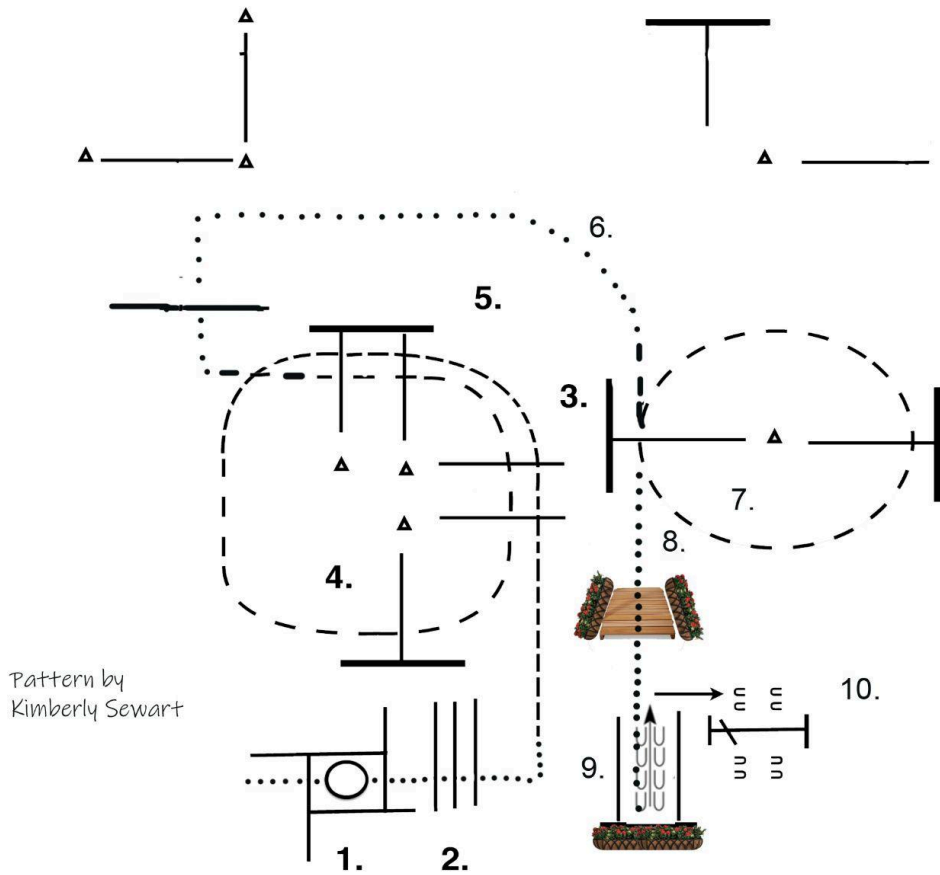

Pattern by
Kimberly Sewart

1. Walk into box, hesitate. Then turn 360 right & walk out.
2. Walk over logs.
3. Jog over 4 poles as shown.
4. Jog over 5 poles left as drawn.
5. Break to walk, walk over pole.
6. Continue at a walk to the right as drawn..
7. Jog over poles in a circle to the left as drawn, then walk.
8. Walk over bridge into chute.
9. Back out of chute to gate.
10. Work gate, left hand push.

- Walk
- Jog - - - - -
- Extended Jog - - - - -
- Lope ————
- Lead Change
- Back
- Marker



2 yr Old In Hand Class Trail 53, 54, 55, 56, 57, 58, 59, 60, 61, 62, 63, 64, 65, 66

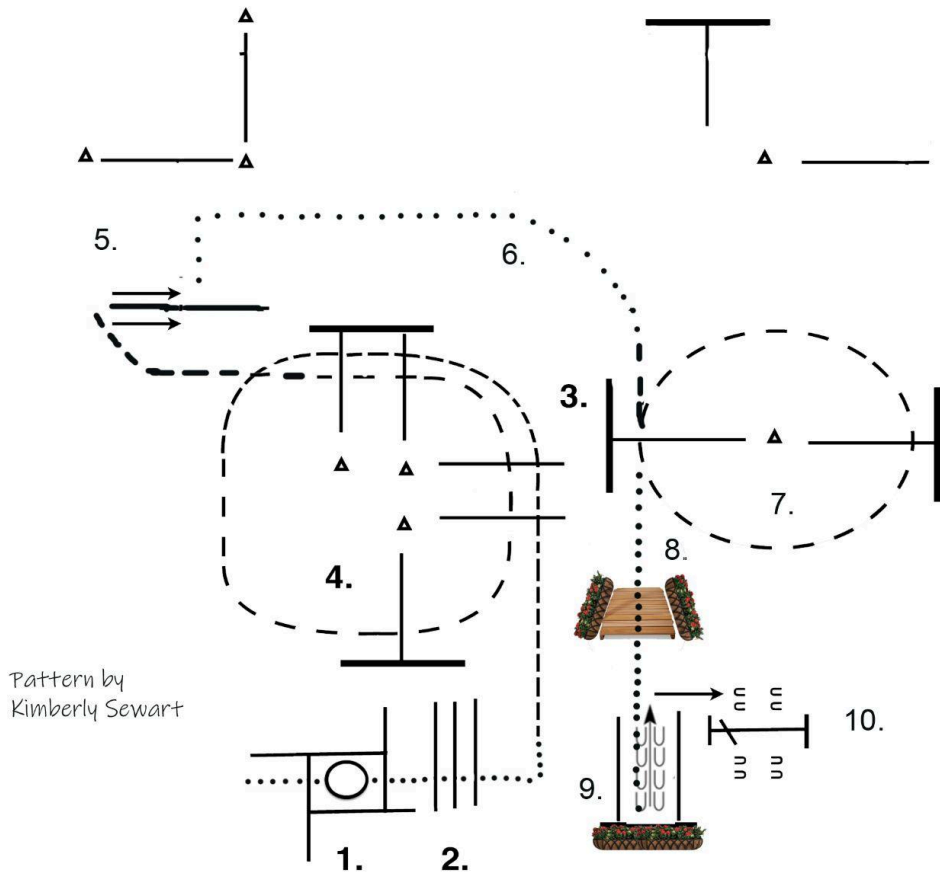

Pattern by Kimberly Sewart

1. Walk into box, hesitate. Then turn 360 right & walk out.
2. Walk over logs.
3. Jog over 4 poles as shown.
4. Jog over 5 poles left as drawn.
5. Jog up to pole. Sidepass to the right 1/2 way across pole.
6. Walk, over log, continue at a walk to the right as drawn..
7. Jog over poles in a circle to the left as drawn, then walk.
8. Walk over bridge into chute.
9. Back out of chute to gate.
10. Work gate, left hand push.

| | |
|--------------|-------|
| Walk | |
| Jog | ----- |
| Extended Jog | ----- |
| Lope | ————— |
| Lead Change | |
| Back | |
| Marker | |

Ranch Trail

Class 90, 91, 92, 93, 94, 803, 94, 95, 96, 97, 98, 99,
804, 100, 101



Class 100 & 101 OPEN GATE
FOR 10 & Under Youth

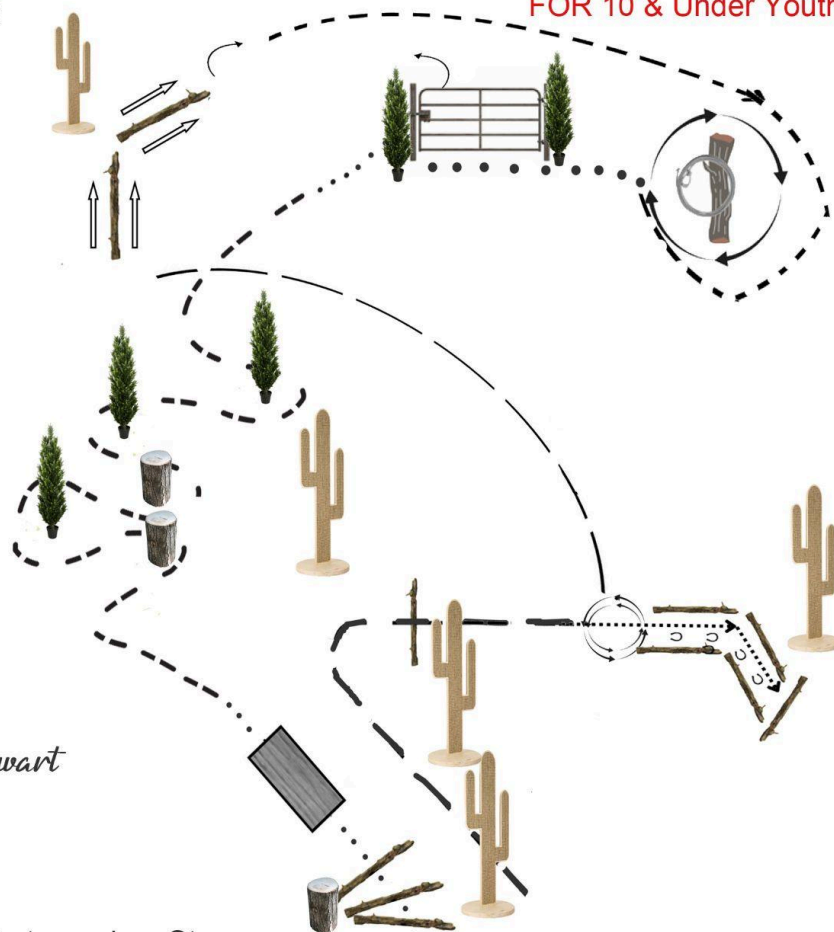

*Pattern by
Kimberly Stewart*

1. Extended Trot over log. Stop.
2. Spin 2 truns to the left. Walk into chute.
3. Back out of chute, Turn 90 degrees.
4. Extended trot to logs. Sidepass right as show.
5. Jog around and up to drag.
6. Drag log to the right at a walk or trot. (Youth will pick up rope and trot circle)
7. Walk to gate. Work gate right (10 & Under walk through open gate)
8. Walk away from gate and towards trees.
9. Jog serpentine.
10. Walk over bridge and logs.

Ranch Fundamental In Hand Trail Lead Line & Walk- Whoa Ranch Trail



Class 102, 103, 104

Class 102 Lead Line/ Walk Whoa
will WALK entire pattern. Handler
will open and close gate.

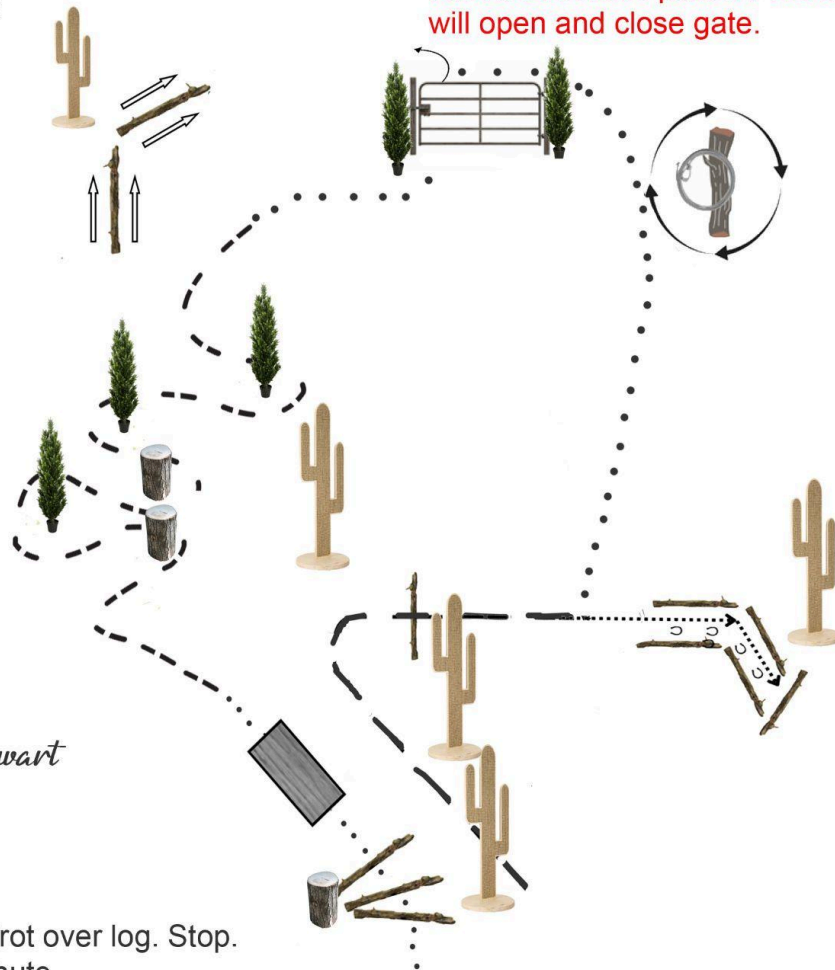

*Pattern by
Kimberly Stewart*

1. Extended Trot over log. Stop.
2. Walk into chute.
3. Back out of chute, Turn 90 degrees.
4. Walk to and around drag.
5. Walk to gate as drawn. Work gate left.
6. Walk away from gate as drawn. Then jog.
7. Jog serpentine.
8. Walk over bridge and logs.



Western Riding Class

105, 106, 107, 108, 109, 110, 111,
112, 113, 114, 115, 116, 117, 118,
119

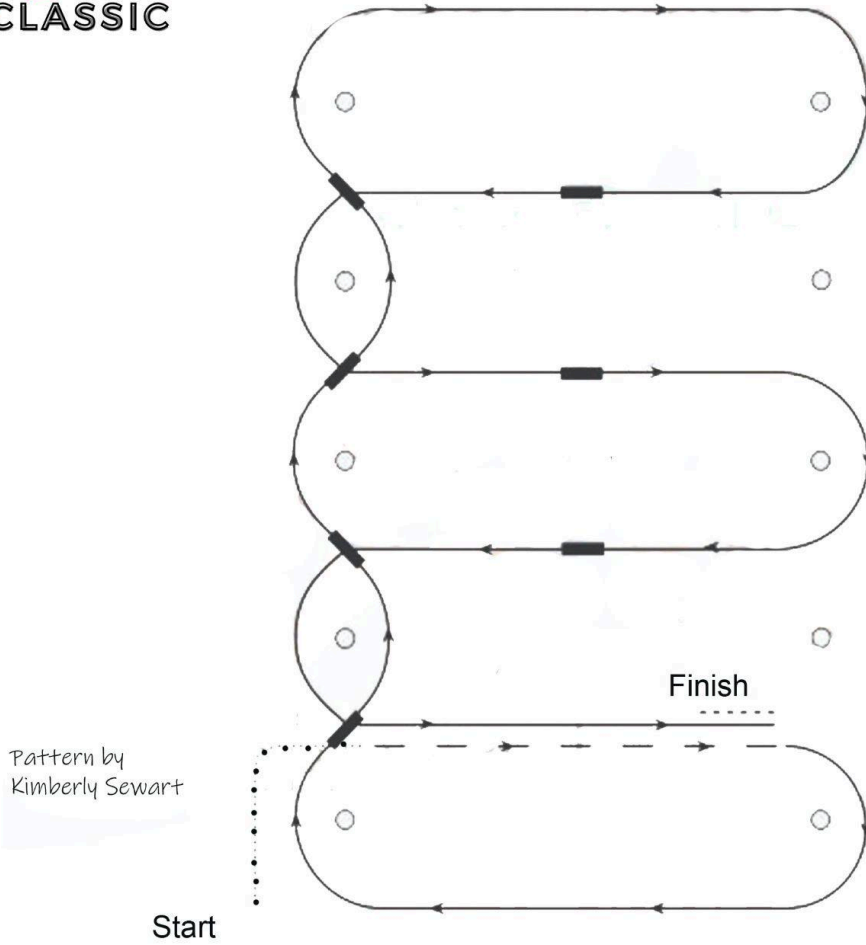

Pattern by
Kimberly Sewart

WESTERN RIDING PATTERN #4

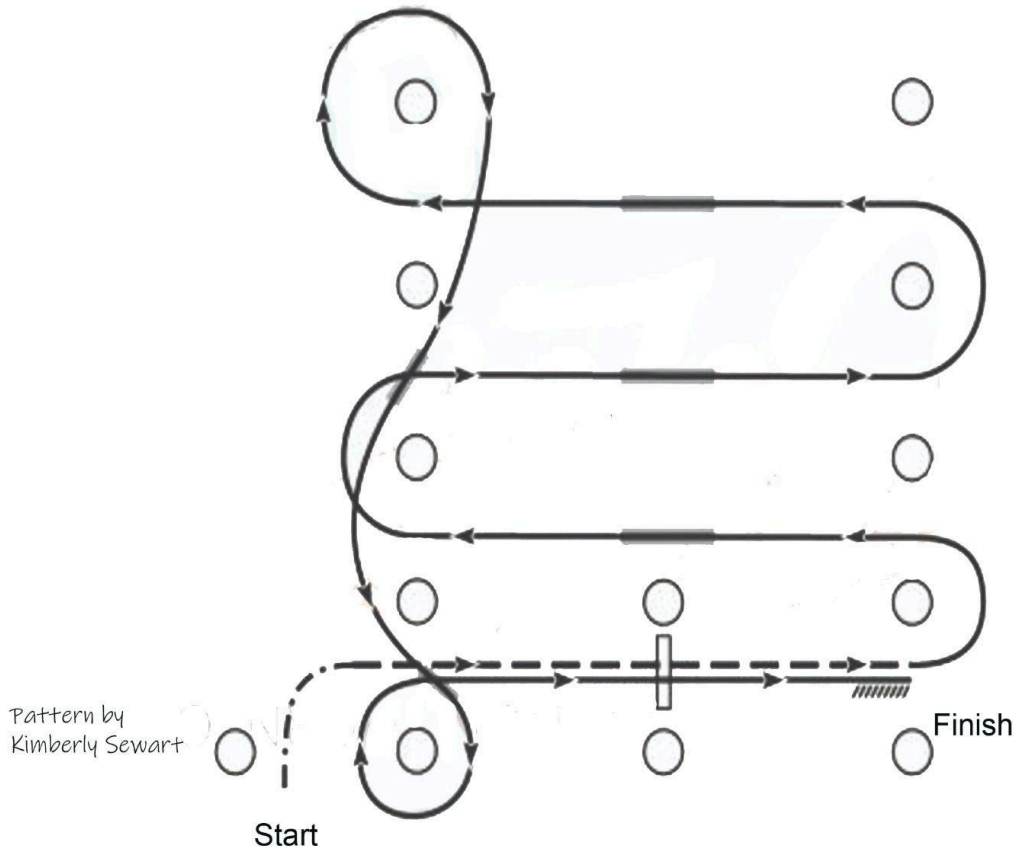

1. Walk, transition to jog, jog over log
2. Transition to right lead lope
3. First line change
4. Second line change
5. Third line change
6. Fourth line change
7. First crossing change
8. Second crossing change
9. Third crossing change
10. Lope over log
11. Lope, stop & back

- Walk
- Jog - - - - -
- Extended Jog - - - - -
- Lope - - - - -
- Lead Change
- Back
- Marker



GREEN WESTERN RIDING PATTERN #2

1. Walk, transition to log, jog over log.
2. Transition to left lead lope
3. First crossing change.
4. Second crossing change.
5. Third crossing change.
6. Circle and first line change.
7. Second line change and circle.
8. Lope over log.
9. Stop and back.

- Walk
- Jog - - - - -
- Extended Jog - - - - -
- Lope ————
- Lead Change 
- Back 
- Marker 



Ranch Reining Class 121, 122, 123, 124, 125, 126, 127, 128,
129, 130, 131, 132, 133, 134, 135, 136, 806 137, 138, 139, 140,
141, 142, 807

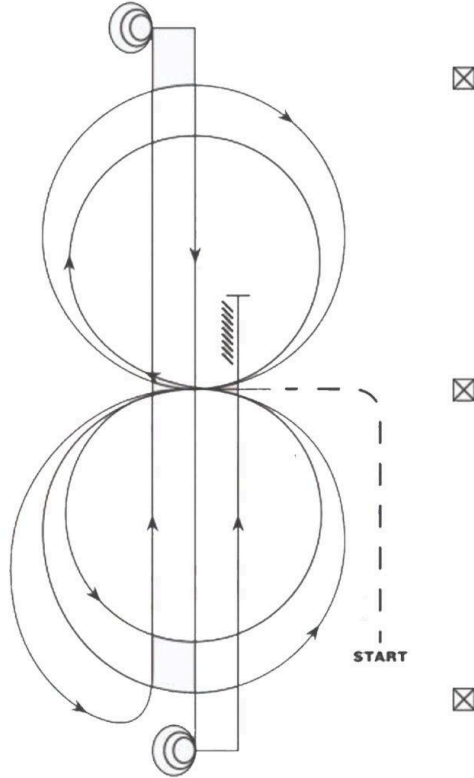

Pattern by
Kimberly Sewart

RANCH REINING #6

Trot to center of arena and stop or walk before departure.
Start pattern facing toward judge.

1. Beginning on left lead, complete two circles to the left - the first one large and fast, the second one small and slow. Change leads at center of arena.
2. Complete two circles to the right - the first one large and fast, the second one small and slow. Change leads at center of arena.
3. Begin a circle to the left, but do not close this circle. Continuing around the end of arena, run up the center, past end marker, and do a sliding stop.
4. Complete 3 1/2 spins to the left.
5. Run down to other end of arena, past the end marker, and do a sliding stop.
6. Complete 3 1/2 spins to the right.
7. Run past the center marker and do a sliding stop. Back at least 10 feet. Hesitate to show completion pattern

- Walk
- Jog - - - - -
- Extended Jog - - - - -
- Lope - - - - -
- Lead Change
- Back
- Marker

Showmanship

Class 232, 233, 234, 235, 236, 237, 238, 239, 240, 241, 242, 243, 244, 245, 246, 247, 248

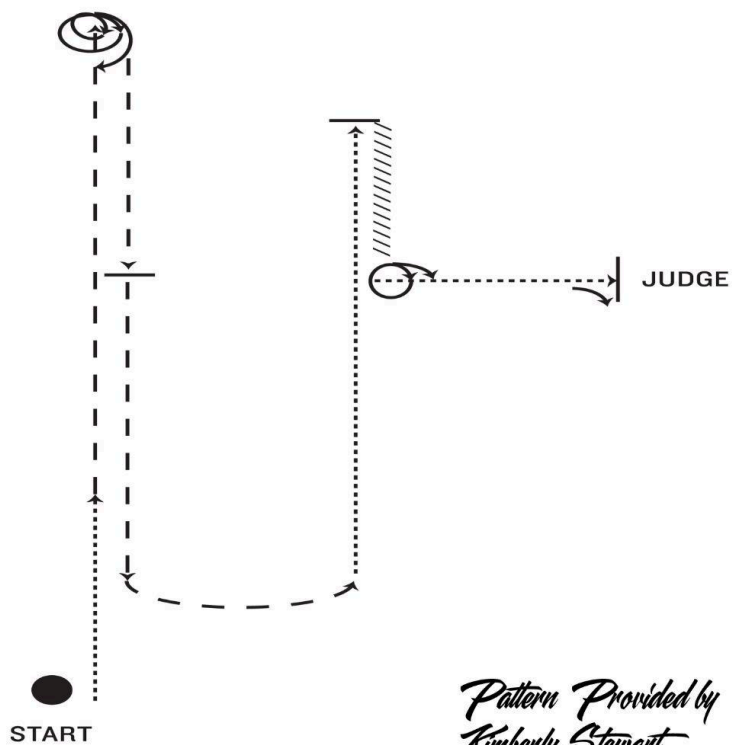

*Pattern Provided by
Kimberly Stewart*

1. From the start cone, walk one-third of the line.
2. Trot two-thirds of the line.
3. Stop. 2 1/2 turns
4. Trot. Stop and set up for brief inspection.
5. Trot, walk.
6. Stop, back, 1 1/4 turn.
7. Walk to judge and set up for full inspection.
8. When dismissed, 1/4 turn then walk or trot to holding pen.

Showmanship Walk / Trot

Class 249, 250, 251, 255, 256, 257, 258, 259, 260, 261, 262, 263

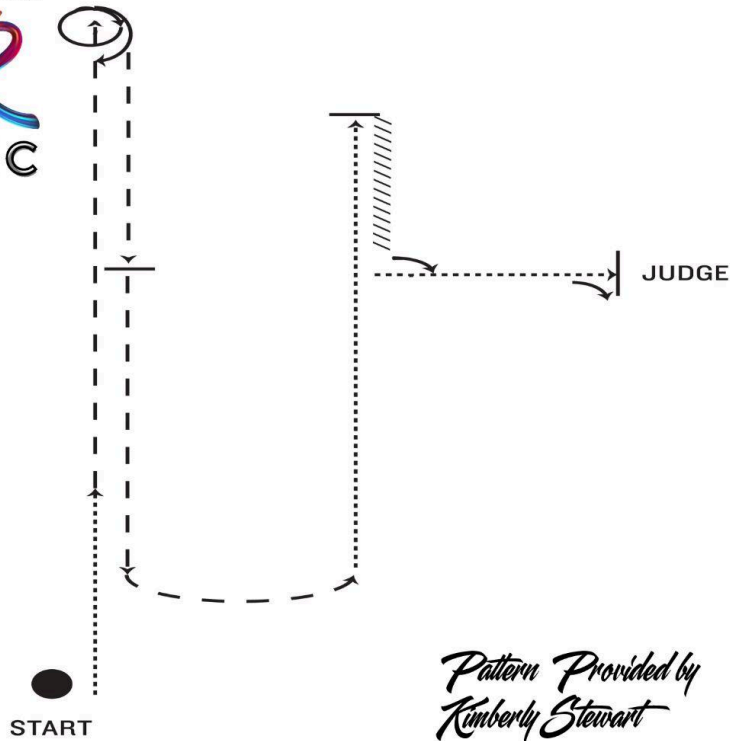

1. From the start cone, walk one-third of the line.
2. Trot two-thirds of the line.
3. Stop. 1 1/2 turns
4. Trot. Stop and set up for brief inspection.
5. Trot, walk.
6. Stop, back, 1/4 turn.
7. Walk to judge and set up for full inspection.
8. When dismissed, 1/4 turn then walk or trot to holding pen.

Showmanship - Walk / Walk

Class 252, 253 & 254

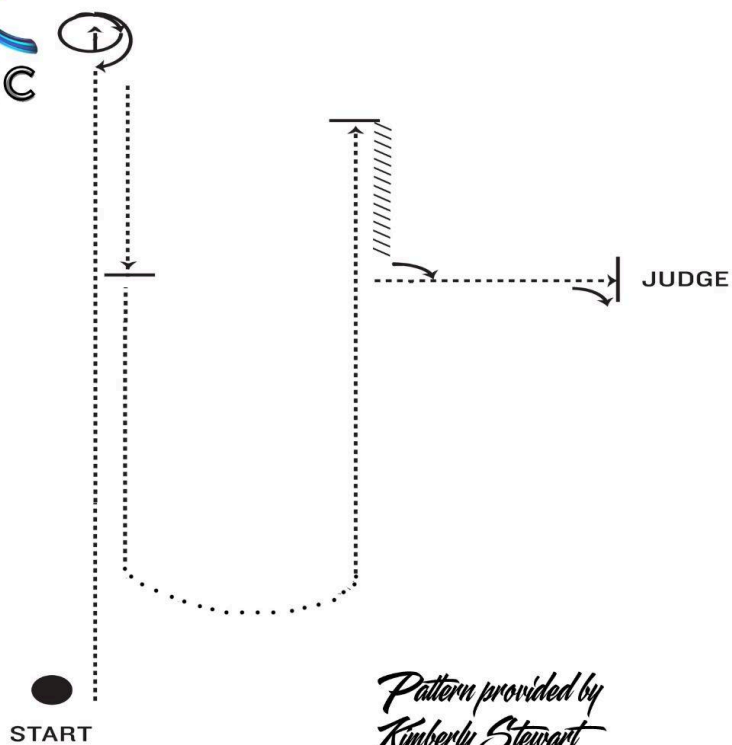

*Pattern provided by
Kimberly Stewart*

1. From the start cone, walk to the end of the line.
2. Stop. 1 1/2 turns
3. Walk. Stop and set up for brief inspection.
4. Walk.
6. Stop, back, 1/4 turn.
7. Walk to judge and set up for full inspection.
8. When dismissed, 1/4 turn then walk to holding pen.

Equitation

Class 334, 335, 336, 337, 338, 339 , 340, 341, 342, 343, 344, 345, 346, 347, 348

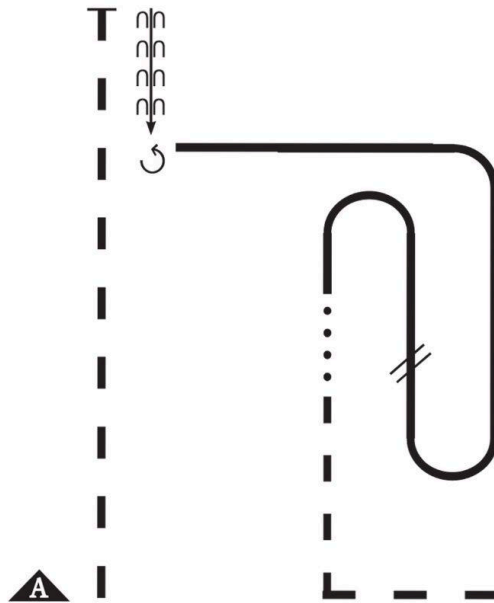

*Pattern Provided by
Kimberly Stewart*

1. Posting trot left diagonal.
2. Half way, change to right diagonal. Stop.
3. Back one horse length.
4. Perform a 270 forehand turn left.
5. Canter right lead.
6. Change leads.
7. Canter left lead.
8. Walk approx. four steps.
9. Sitting trot square corner to exit.

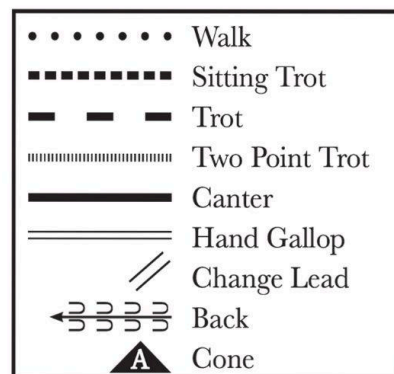

Novice Equitation

Class 349, 350

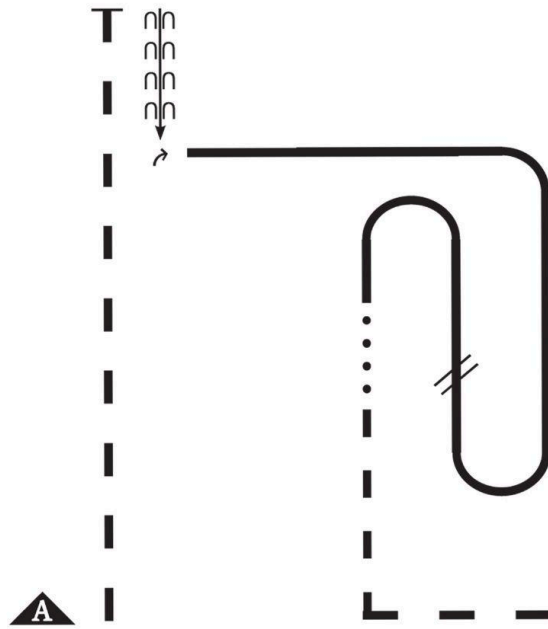

*Pattern Provided by
Kimberly Stewart*

1. Posting trot left diagonal.
2. Half way chagne to right diagonal, then stop.
3. Back one horse length.
4. Perform a 90 degree forehand turn right.
5. Canter right lead.
6. Change leads.
7. Canter left lead.
8. Walk approximately 4 steps.
9. Sitting trot square corner to exit.

| | |
|-----------|----------------|
| | Walk |
| ----- | Sitting Trot |
| - - - - - | Trot |
| | Two Point Trot |
| ————— | Canter |
| ===== | Hand Gallop |
| // | Change Lead |
| ← ⊞ ⊞ ⊞ ⊞ | Back |
| ▲ | Cone |

Equitation Walk / Trot

Class 351, 352, 353, 354, 355, 356, 357, 358, 359, 360, 361, 362, 363, 364, 365

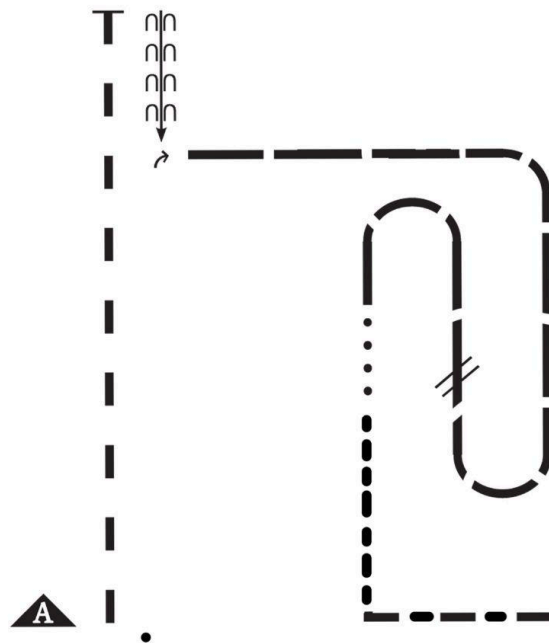

*Pattern Provided by
Kimberly Stewart*

1. Posting trot left diagonal.
2. Half way chagne to right diagonal, then stop.
3. Back one horse length.
4. Perform a 90 degree forehand turn right.
5. Extended trot left diagonal.
6. Extended trot right diagonal.
7. Walk approximately 4 steps
8. Sitting trot square corner to exit.

| | |
|-----------|----------------|
| | Walk |
| ----- | Sitting Trot |
| - - - - - | Trot |
| | Two Point Trot |
| ===== | Extended Trot |
| ===== | Hand Gallop |
| // | Change Lead |
| ← ⊞ ⊞ ⊞ ⊞ | Back |
| ▲ A | Cone |

Ranch Riding

Class 365, 366, 705, 367, 368, 369, 370, 371, 808, 372, 373, 374, 375, 376, 377, 378, 379, 380, 381, 809, 382, 383, 384, 385, 386, 387, 810

Instructions

Pattern #15

1. Extended trot
2. Stop, roll back right
3. Lope right lead
4. Extended lope (right lead)
5. Trot
6. Walk
7. Walk over logs
8. Walk
9. Trot
10. Stop, 360 left
11. Lope left lead
12. Stop and back

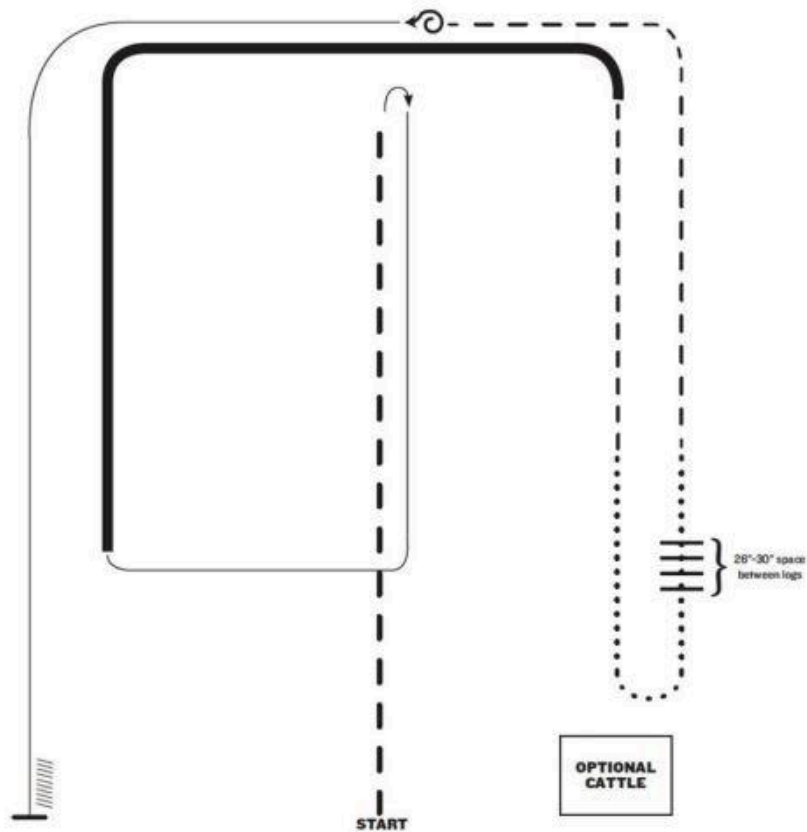

Ranch Riding Walk - Trot

Class 388, 389, 390, 391, 392, 811, 393, 394, 395, 396, 397, 812, 398, 399



Instructions

Pattern #15

1. Extended Trot
2. Stop, roll back right
3. Trot
4. Extended Trot
5. Trot
6. Walk
7. Walk over logs
8. Walk
9. Trot
10. Stop, 360 left
11. Extended Trot
12. Stop and back

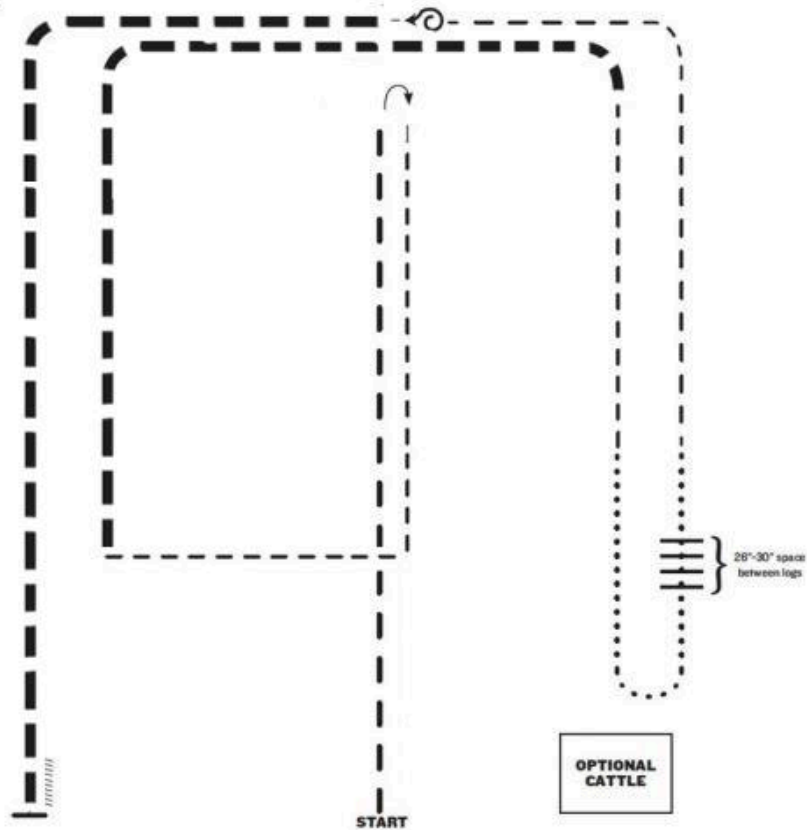

Leadline Horsemanship/ Equitation/ Ranch Horsemanship

Class 445

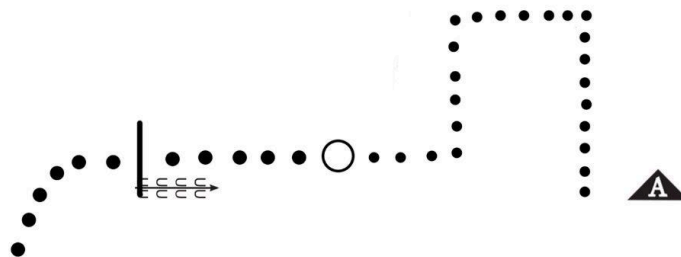

*Pattern Provided by
Kimberly Stewart*

1. Walk, walk square corner to left.
2. Continue walk and square corner to the right..
3. Continue to walk, then stop.
4. Complete a 360 degree pivot to the right.
5. Walk.
7. Stop. Back 1 horse length.
8. Exit at a walk.

| | |
|-----------|---------------|
| | Walk |
| ----- | Jog |
| - - - - | Extended Jog |
| ———— | Lope |
| ===== | Extended Lope |
| /// | Lead Change |
| ← ⊃ ⊃ ⊃ ⊃ | Back |
| ▲ A | Cone |

Horsemanship

Class 446, 447, 448, 449, 450, 451, 452, 453, 454, 455, 456, 457, 458, 459, 460, 461, 462

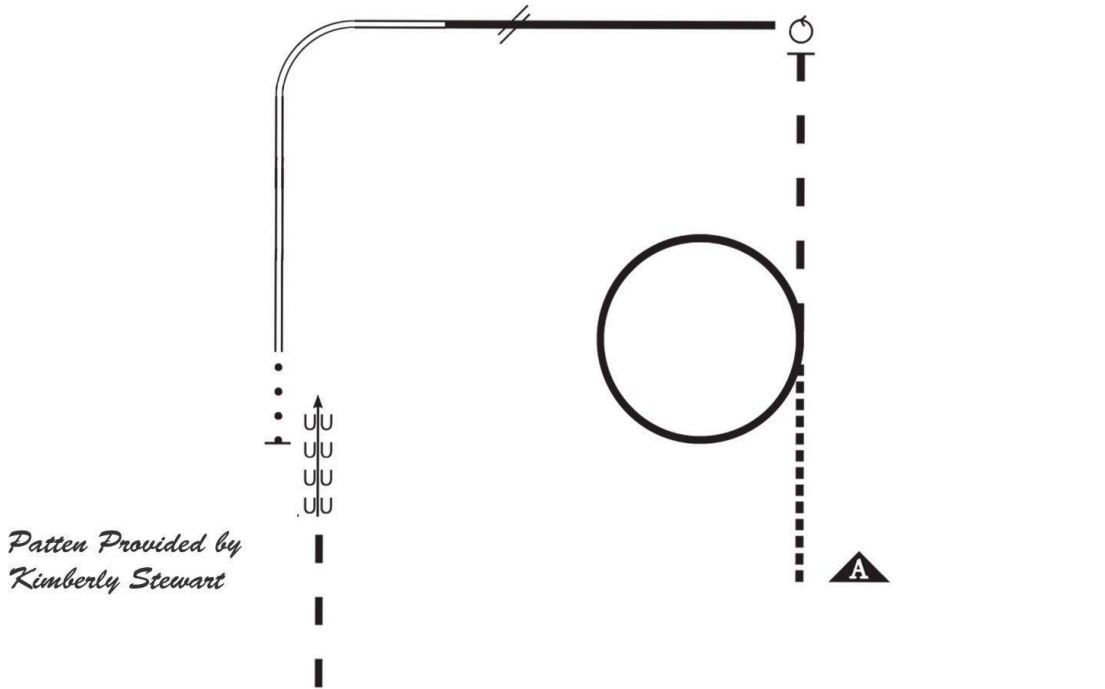

1. Jog
2. Lope left lead circle.
3. Extended jog
4. Stop. Perform a 450 turn to the left.
5. Lope right lead.
6. Change leads. Continue left lead lope.
7. Extended lope corner.
8. Walk.
9. Stop. Back one horse length.
10. Exit at extended jog.

| | |
|-----------|---------------|
| | Walk |
| ----- | Jog |
| - - - - - | Extended Jog |
| ————— | Lope |
| ═══════ | Extended Lope |
| /// | Lead Change |
| ← ⊞ ⊞ ⊞ ⊞ | Back |
| ▲ A | Cone |

Novice Horsemanship

Class 461, 462

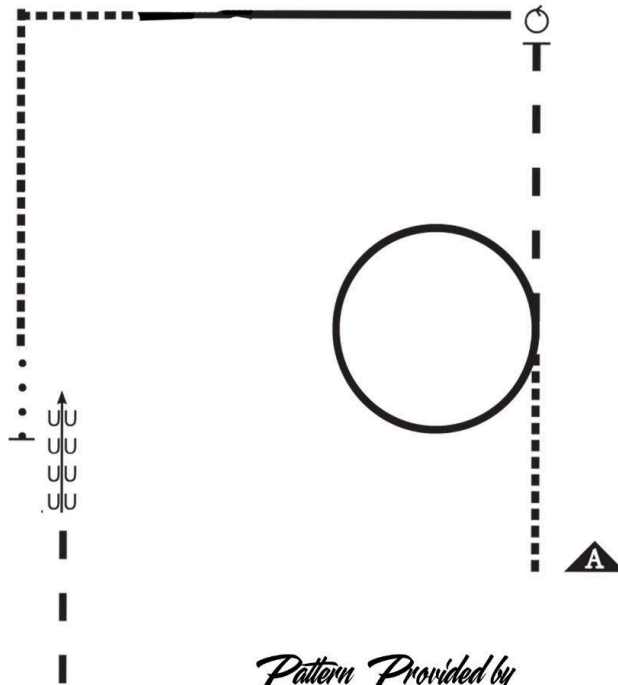

*Pattern Provided by
Kimberly Stewart*

1. Jog
2. Lope left lead circle.
3. Extended jog.
4. Stop. Perform a 450 turn to the left.
5. Right lead.
6. Jog, jog corner.
7. Walk.
8. Stop. Back one horse length.
9. Exit at extended jog.

| | |
|-----------|---------------|
| | Walk |
| ----- | Jog |
| - - - - - | Extended Jog |
| ————— | Lope |
| ===== | Extended Lope |
| //// | Lead Change |
| ← ⊞ ⊞ ⊞ ⊞ | Back |
| ▲ | Cone |

Horsemanship Walk / Trot

Class 463, 464, 465, 466, 467, 468, 469, 470, 471, 472, 473, 474, 475, 476, 477

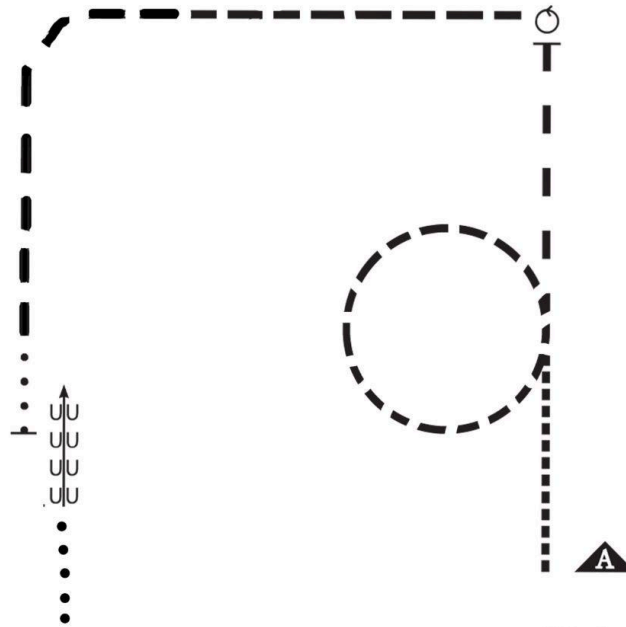

*Pattern Provided by
Kimberly Stewart*

1. Jog
2. Extended jog left circle.
3. Continue to jog. Stop.
4. Complete a 450 degree pivot to the left.
5. Extended jog and continue around the corner.
6. Break to walk.
7. Stop. Back 1 horse length.
8. Exit at a walk.

| | |
|-----------|---------------|
| | Walk |
| ----- | Jog |
| - - - - - | Extended Jog |
| ————— | Lope |
| ===== | Extended Lope |
| // | Lead Change |
| ← ⊞ ⊞ ⊞ ⊞ | Back |
| ▲ | Cone |