

SPRING  DON THORNTON  
AUTOMOTIVE GROUP  
**Color**  
CLASSIC

Oklahoma Pinto Horse Association



# PATTERN BOOK

# 2025

\*\*Please note, Buckskin Bred classes will have the same patterns for their classes as its corresponding Buckskin class.

Trail- Class 1, 2, 3, 4, 5, 6, 7, 8, 9, 10, 11, 12, 13, 14, 15, 16, 17, 18,  
19, 20, 21, 22, 23

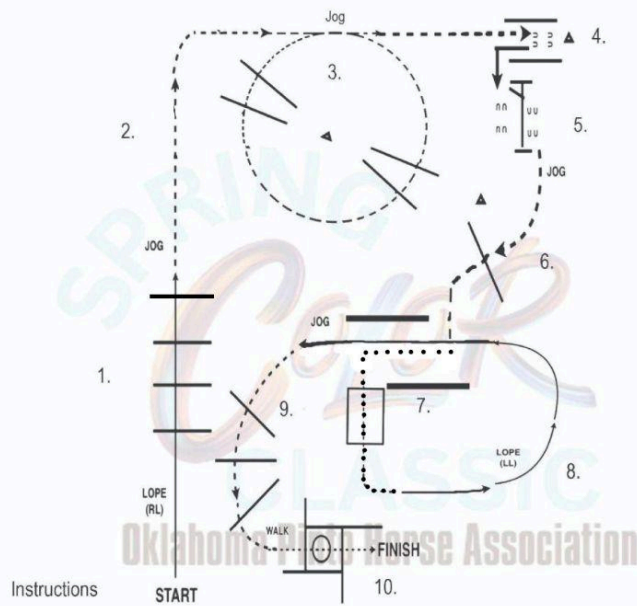

Instructions

1. Lope right lead over poles.
2. Jog around corner, right.
3. Jog in a circle over poles.
4. Jog into chute, stop and back L to gate.
5. Work gate **right**
6. Jog over pole.
7. Walk over bridge.
8. Lope left lead in a half circle left.
9. Trot over logs.
10. Walk. Walk into box, 360 either direction. Hesitate, walk out, walk to exit.

Trail- Class 24, 25, 26, 27, 28, 29, 30, 31, 32, 33, 34, 35, 36

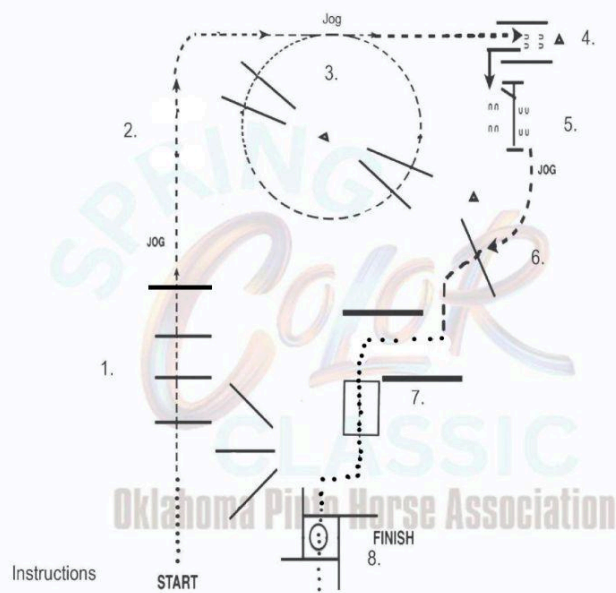

Instructions

1. Begin at a walk, then jog, jog over poles.
2. Jog around corner, right.
3. Jog in a circle over poles.
4. Jog into chute, stop and back L to gate.
5. Work gate **right** (Youth classes 10 & Under and 5 - 10 walk through open gate.)
6. Jog over pole.
7. Walk over bridge.
8. Walk into box. Turn a 360 either direction. Hesitate, walk out, walk to exit.

## Trail- Class 37, 38, 39, 40, 41, 42, 43, 44, 45

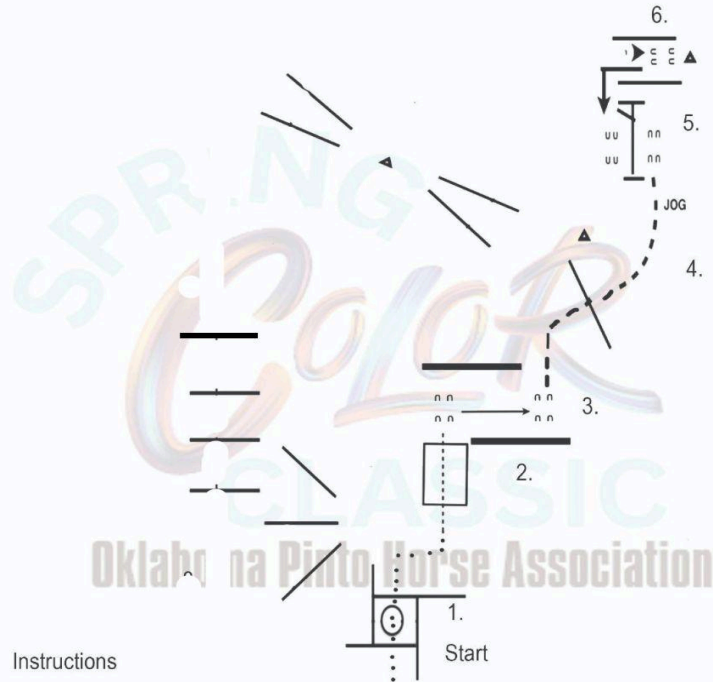

### Instructions

1. Walk into box, complete a 360 to the right. Walk out of box.
2. Walk over bridge.
3. Sidepass right.
4. Trot over pole towards gate.
5. Work gate. **left**.
6. Back L into chute. Walk out, pattern complete.

walk to exit along the wall of the arena.

## Ranch Trail- Class 46, 47, 48, 49, 50

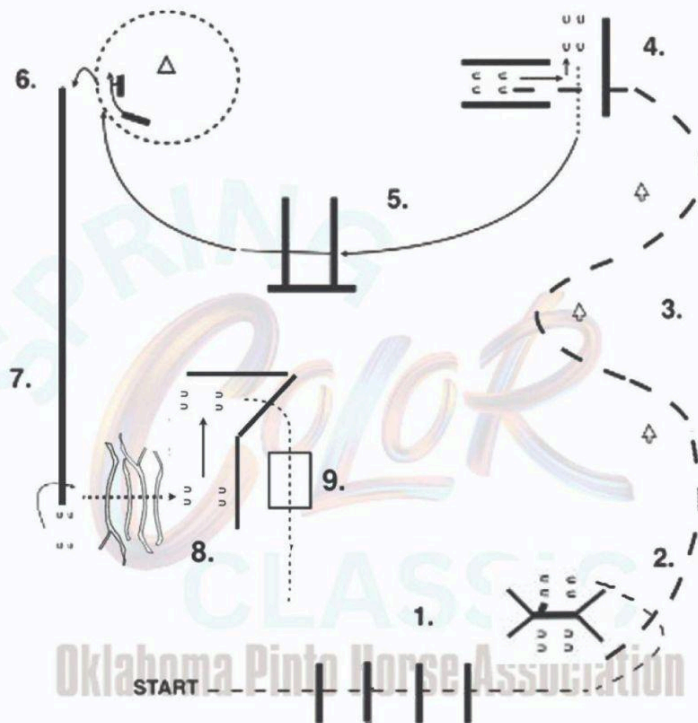

1. Trot over logs to gate.
2. Work gate
3. Extended Trot through serpentine around markers into chute.
4. Back through chute as drawn. Walk out of chute.
5. Right lead lope over logs to drag.
6. Drag log to the left around marker. (walk or trot)
7. Left lead extended lope to logs, then stop and perform a 3/4 turn to the right.
8. Walk over logs and sidepass left.
9. Walk over log and bridge. Walk to exit.

Ranch Trail- Class 51, 52,53, 54, 55, 56, 57,58, 59  
60, 61, 62, 63, 64

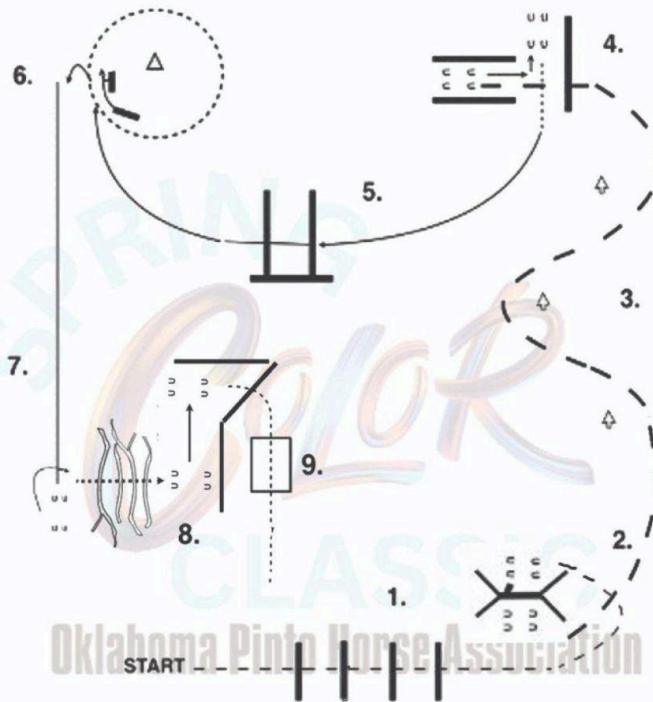

1. Trot over logs to gate.
2. Work gate .
3. Extended Trot through serpentine around markers into chute.
4. Back through chute as drawn. Walk out of chute.
5. Right lead lope over logs to drag.
6. Drag log to the right around marker. (walk or trot)
7. Left lead lope to logs, then stop and perform a 3/4 turn to the right.
8. Walk over logs and sidepass left.
9. Walk over log and bridge. Walk to exit.

**YOUTH IN YOUTH CLASSES DO NOT DRAG LOG. YOUTH WILL PICK UP ROPE, TROT AROUND MARKER THEN REPLACE ROPE.**

## Ranch Trail- Class 65, 66, 67, 68

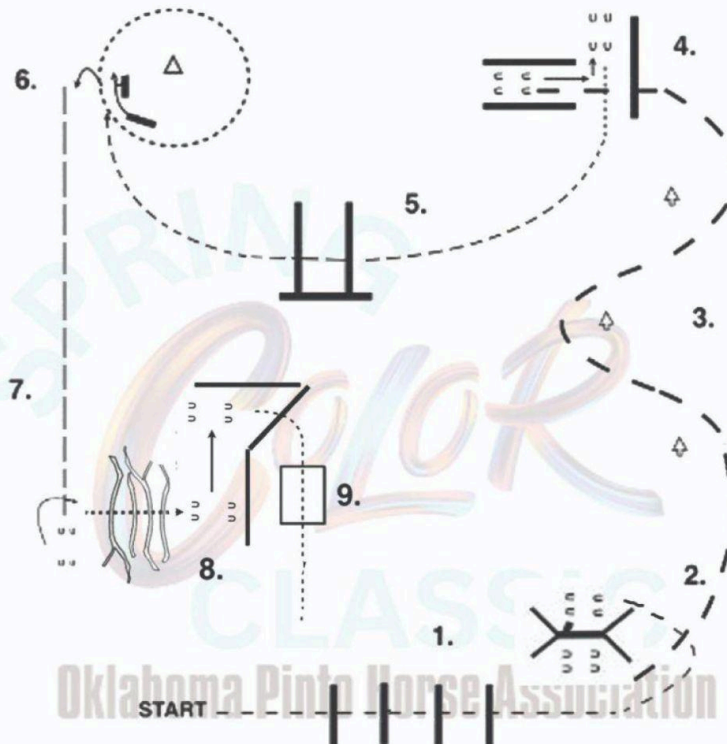

1. Trot over logs to gate.
2. Work gate
3. Extended Trot through serpentine around markers into chute.
4. Back through chute as drawn. Walk out of chute.
5. Trot over logs to drag.
6. Drag log right around marker (walk or trot).
7. Extended trot to logs, then stop and perform a 3/4 turn to the right.
8. Walk over logs and sidepass left.
9. Walk over log and bridge. Walk to exit.



## Ranch Trail- Class 69, 70,71,72,73, 74

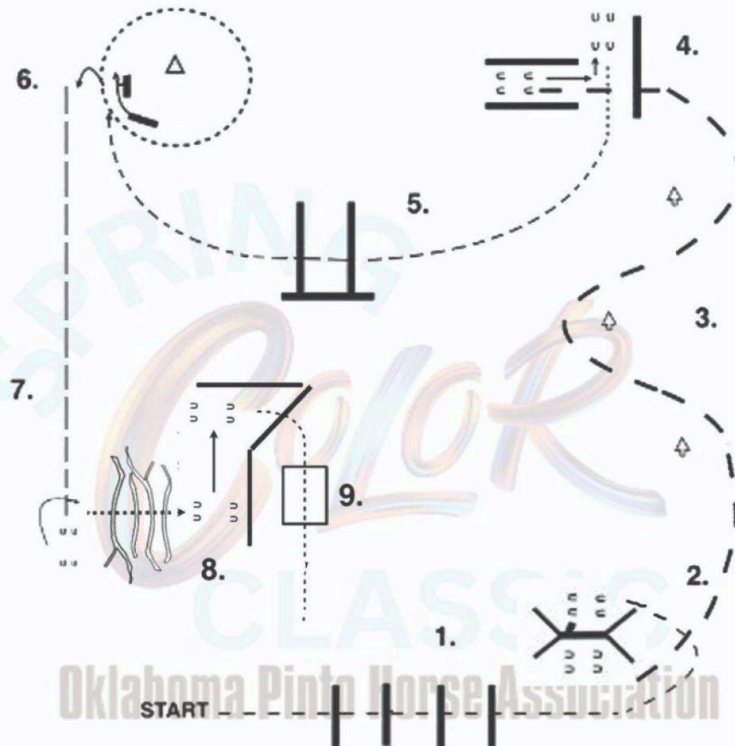

1. Trot over logs to gate.
2. Work gate (Class 72, 73, 74 walk through open gate)
3. Extended Trot through serpentine around markers into chute.
4. Back through chute as drawn. Walk out of chute.
5. Trot over logs to drag.
6. Pick up rope, left around marker (walk or trot). Replace rope.
7. Extended trot to logs, then stop and perform a 3/4 turn to the right.
8. Walk over logs and sidepass left.
9. Walk over log and bridge. Walk to exit.



## Ranch Trail- Class '75

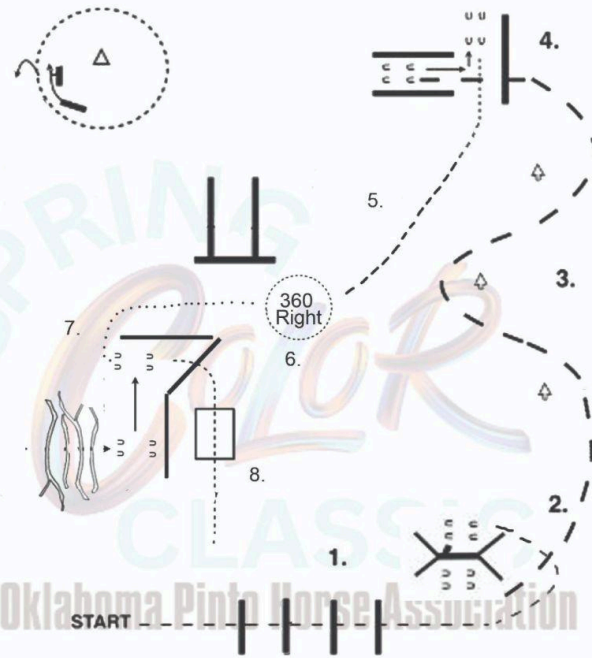

1. Trot over logs to gate.
2. Work gate left.
3. Trot through serpentine around markers into chute.
4. Back through chute as drawn.
5. Trot, then stop.
6. Execute a 360 turn to the right.
7. Walk around log as drawn.
8. Walk over log and bridge. Walk to exit.

Western Riding Class 76,77, 78, 79, 80, 81, 82,  
83, 84, 85, 86, 87, 88, 89, 90

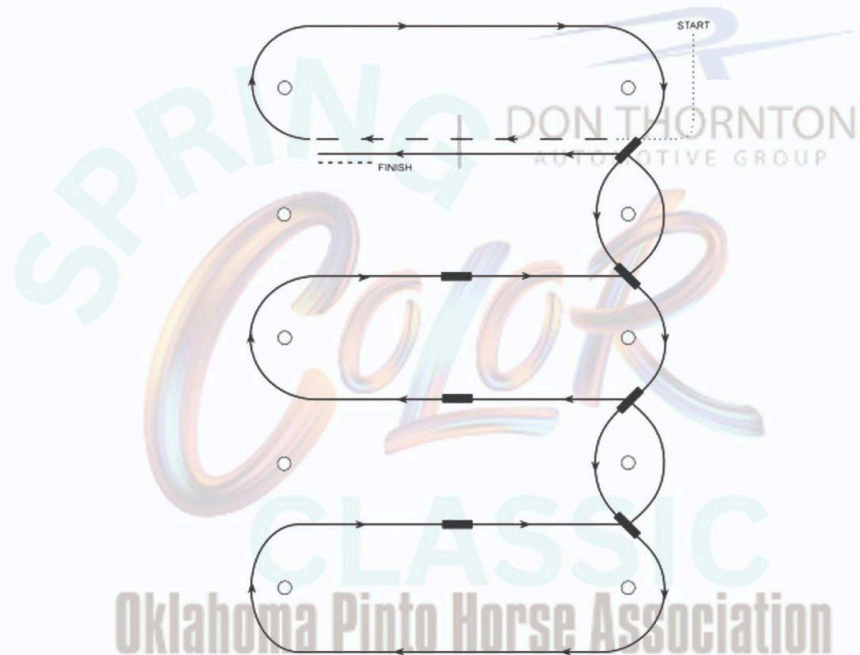

**WESTERN RIDING PATTERN #4**

1. Walk, transition to jog, jog over log
2. Transition to right lead lope
3. First line change
4. Second line change
5. Third line change
6. Fourth line change
7. First crossing change
8. Second crossing change
9. Third crossing change
10. Lope over log
11. Lope, stop & back

## Green Western Riding Class 91

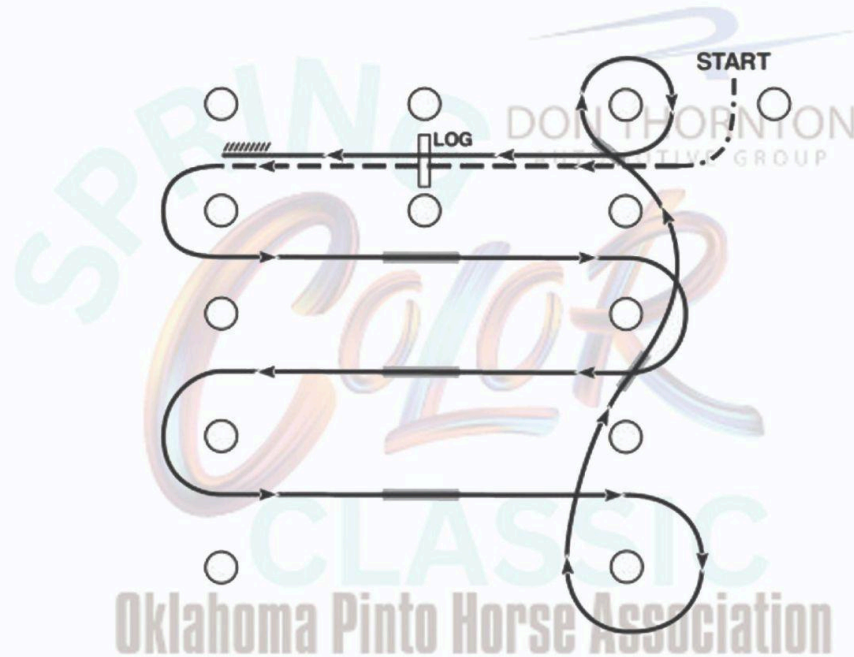

### GREEN WESTERN RIDING PATTERN #2

1. Walk, transition to log, jog over log.
2. Transition to left lead lope
3. First crossing change.
4. Second crossing change.
5. Third crossing change.
6. Circle and first line change.
7. Second line change and circle.
8. Lope over log.
9. Stop and back.

Ranch Reining Class 92, 93, 94, 95, 96, 97, 98, 99, 100,  
101, 102, 103, 104, 105, 106, 107, 108, 109, 110

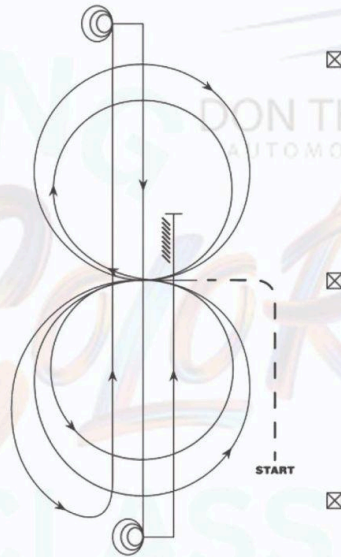

**RANCH REINING #6**

Trot to center of arena and stop or walk before departure.  
Start pattern facing toward judge.

1. Beginning on left lead, complete two circles to the left - the first one large and fast, the second one small and slow. Change leads at center of arena.
2. Complete two circles to the right - the first one large and fast, the second one small and slow. Change leads at center of arena.
3. Begin a circle to the left, but do not close this circle. Continuing around the end of arena, run up the center, past end marker, and do a sliding stop.
4. Complete 3 1/2 spins to the left.
5. Run down to other end of arena, past the end marker, and do a sliding stop.
6. Complete 3 1/2 spins to the right.
7. Run past the center marker and do a sliding stop. Back at least 10 feet. Hesitate to show completion pattern

Showmanship Class 209,210, 211, 212,  
213, 214, 215, 216, 217, 218, 219, 220, 221

---

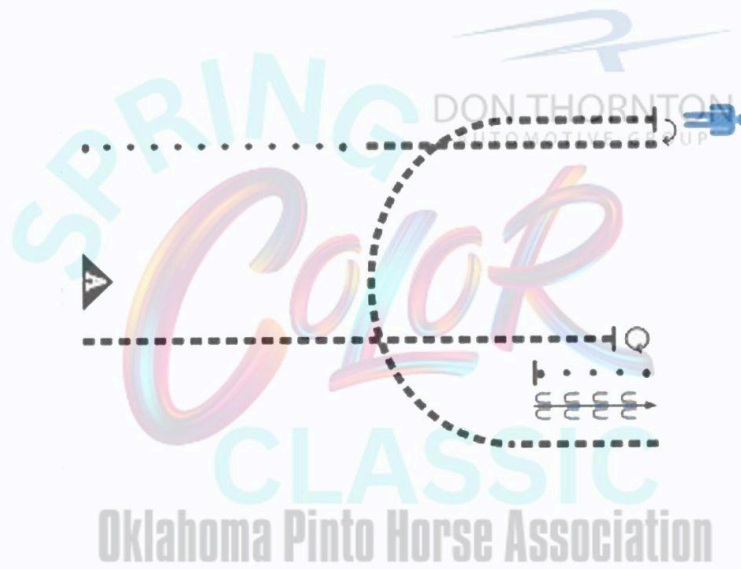

1. Trot
2. Stop. Perform a 540 degree turn.
3. Walk 4 - 5 steps.
4. Stop. Back 4 - 5 steps.
5. Trot 1/2 circle to judge.
6. Stop and set up.
7. Inspection.
8. Perform a 180 degree turn.
9. Trot. Once past the arc, walk to exit.

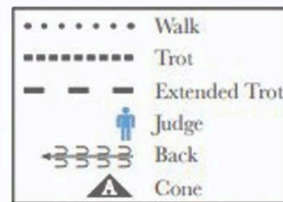

Showmanship Class 222, 223, 224, 225, 229,  
230, 231, 232, 233, 234, 235, 236

---



1. Trot
2. Stop. Perform a 180 degree turn
3. Walk 4 - 5 steps.
4. Stop. Back 4 -5 steps.
5. Trot 1/2 circle to judge.
6. Stop and set up.
7. Inspection.
8. Perform a 180 degree turn.
9. Trot. Once past the arc, walk to exit.

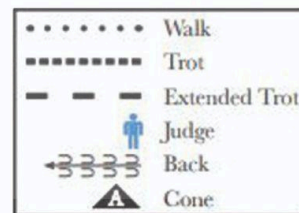

## Showmanship Walk/ Walk (W/W) Class 226, 227, 228

---



1. Walk
2. Stop. Perform a 180 degree turn.
3. Walk 4-5 steps.
4. Stop. Back 4-5 steps.
5. Walk 1/2 circle to judge.
6. Stop and set up.
7. Inspection.
8. Perform a 180 degree turn.
9. Walk. Walk to exit.

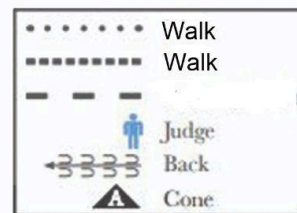



Equitation Class 287, 288, 289, 290, 291, 292,  
293, 294, 295, 296, 297, 298, 299 , 300, 301

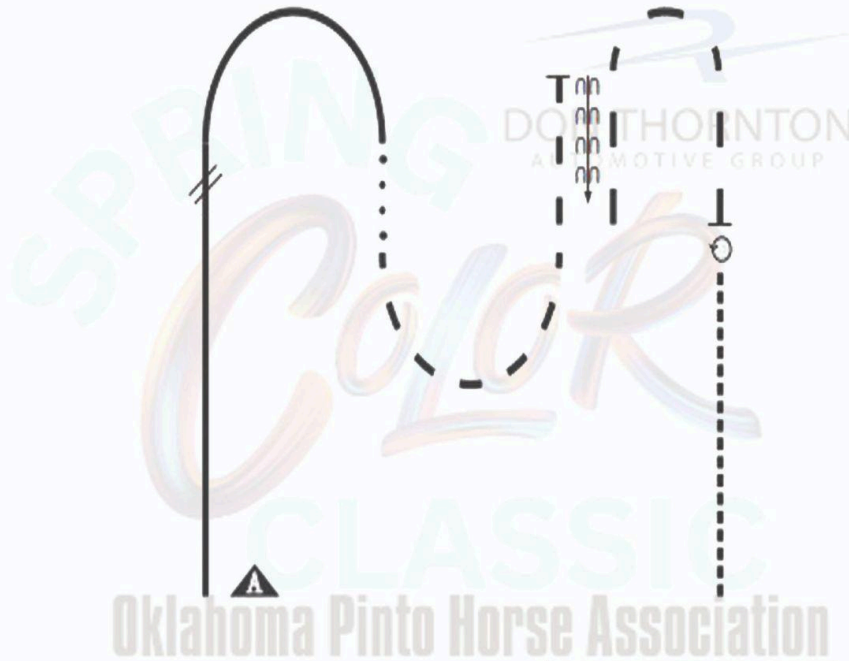

1. Canter left lead.
2. Change leads.
3. Canter right lead.
4. Walk 4 to 5 setps.
5. Posting trot right diagonal.
6. Stop and back.
7. Posting trot left diagonal.
8. Stop, performa a 360 degree turn left on forehand.
9. Exit at a sitting trot.

.....	Walk
-----	Sitting Trot
- - - - -	Trot
=====	Two Point
—————	Canter
=====	Hand Gallop
//	Change Lead
←←←←	Back
▲	Cone

Equitation W/T Class 302, 303, 304, 305, 306  
 307, 308, 309, 310, 311, 312, 313, 314



1. Posting trot left diagonal.
2. Sitting trot.
3. Walk 4 to 5 steps
4. Posting trot right diagonal.
5. Stop and back.
6. Stop, perform a 180 degree turn right on forehand.
7. Sitting trot to exit.

.....	Walk
.....	Sitting Trot
- - - -	Trot
	Two Point
————	Canter
=====	Hand Gallop
///	Change Lead
←3333	Back
▲	Cone

Ranch Riding Class 315, 316, 317, 318, 319, 320,  
321, 322, 323, 324, 325, 326, 327, 328, 329, 330, 331, 332, 333

**RANCH RIDING -- PATTERN #9**

1. Trot
2. Trot two sets of logs
3. Trot circle, stop and side pass log left
4. Walk
5. Lope right lead
6. Change leads (simple or flying)
7. Lope left lead
8. Extended lope (left lead)
9. Extended trot
10. Trot
11. Walk
12. Stop and back
13. 360 degree turn each direction (either direction 1st) (L-R or R-L)

Ranch Riding Class 334, 335, 336, 337, 338, 339, 340, 341,  
342, 343

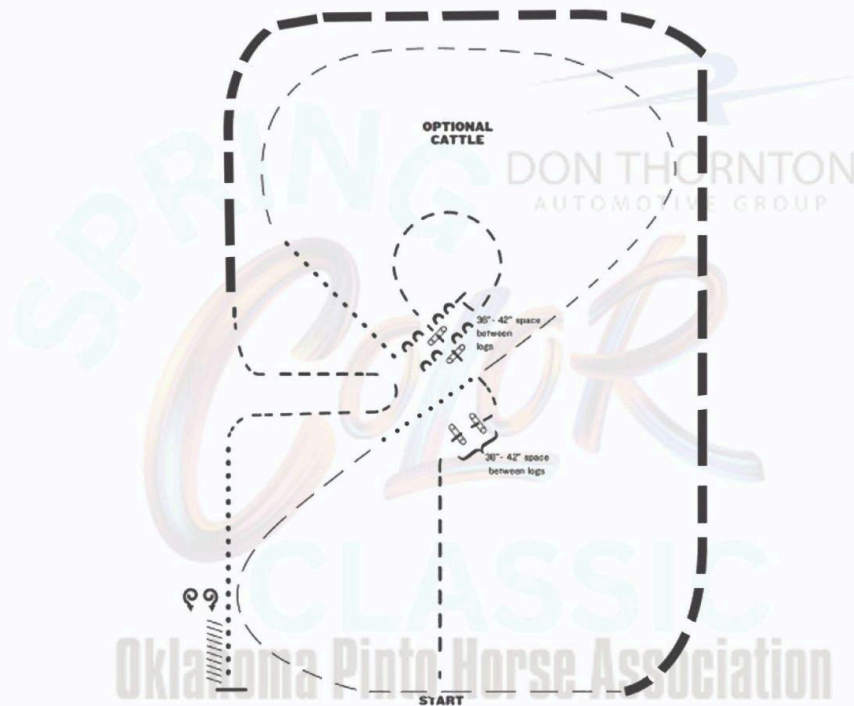

Ranch Riding- Pattern #9 (Modified W/T)

1. Trot
2. Trot two sets of logs.
3. Trot circle, stop and side pass left.
- 4 Walk
5. Trot
6. Walk
7. Trot
8. Extended trot
9. Trot
10. Walk
11. Stop and back.
12. 360 degree turn each direction (either direction first) R-L or L-R

Horsemanship Class 426, 427, 428, 429, 430, 431, 432, 433,  
434, 435, 436, 437, 438, 439, 440

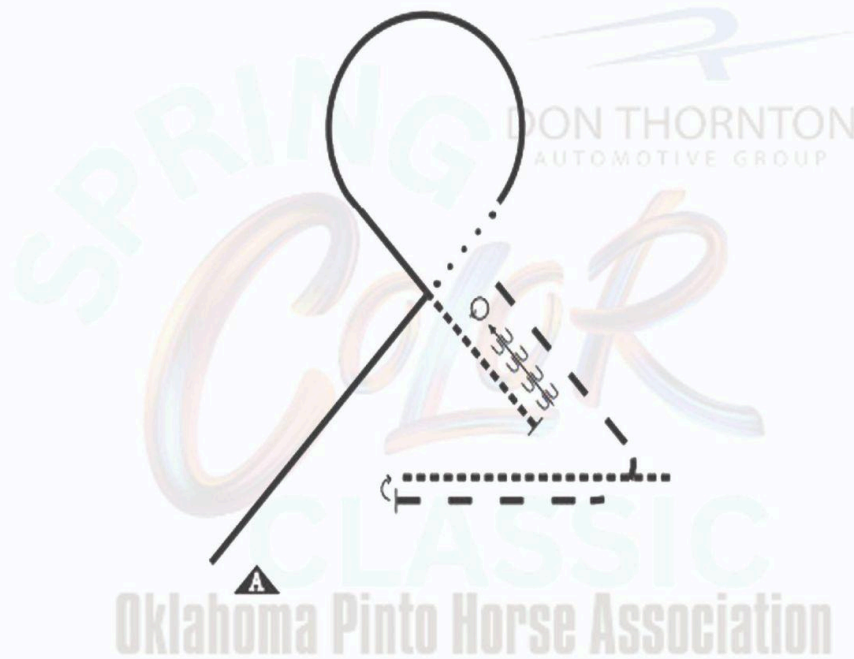

1. Lope right lead.
2. Walk.
3. Lope left lead.
4. Jog.
5. Stop and back.
6. Perform a 360 degree turn left.
7. Extended jog.
8. Stop, perform 180 degree turn right.
9. Jog to exit.

.....	Walk
-----	Jog
- - - -	Extended Jog
————	Lope
=====	Extended Lope
////	Lead Change
←←←←	Back
▲	Cone

Horsemanship Class 441, 442, 443, 444, 445, 446, 447, 448,  
449, 450, 451, 452, 453

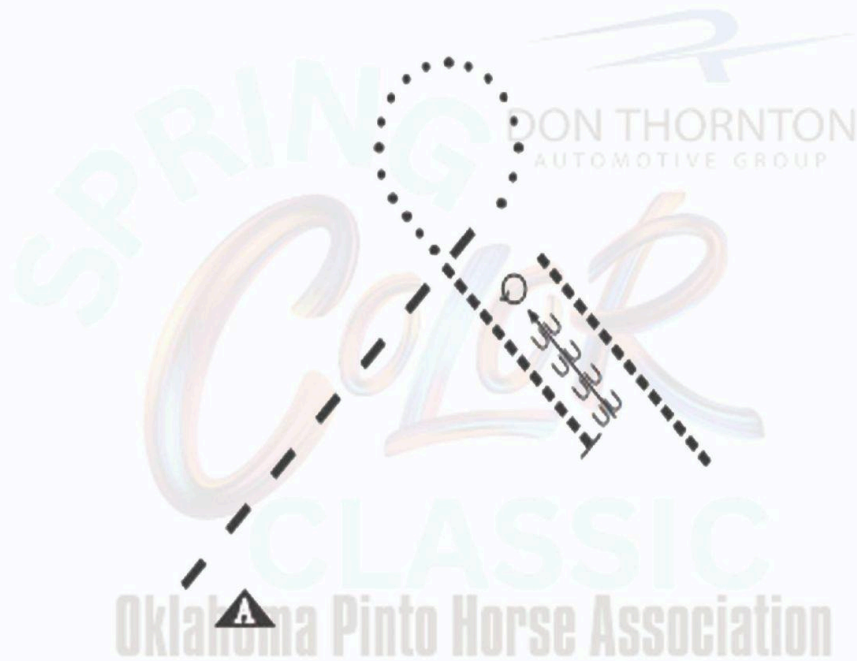

1. Extended jog.
2. Walk.
3. Jog.
4. Stop and back.
5. Perform a 360 degree turn left.
7. Jog to exit.

.....	Walk
-----	Jog
- - - -	Extended Jog
————	Lope
=====	Extended Lope
////	Lead Change
←←←←	Back
▲	Cone



Pattern Book





# RANCH TRAIL YOUTH

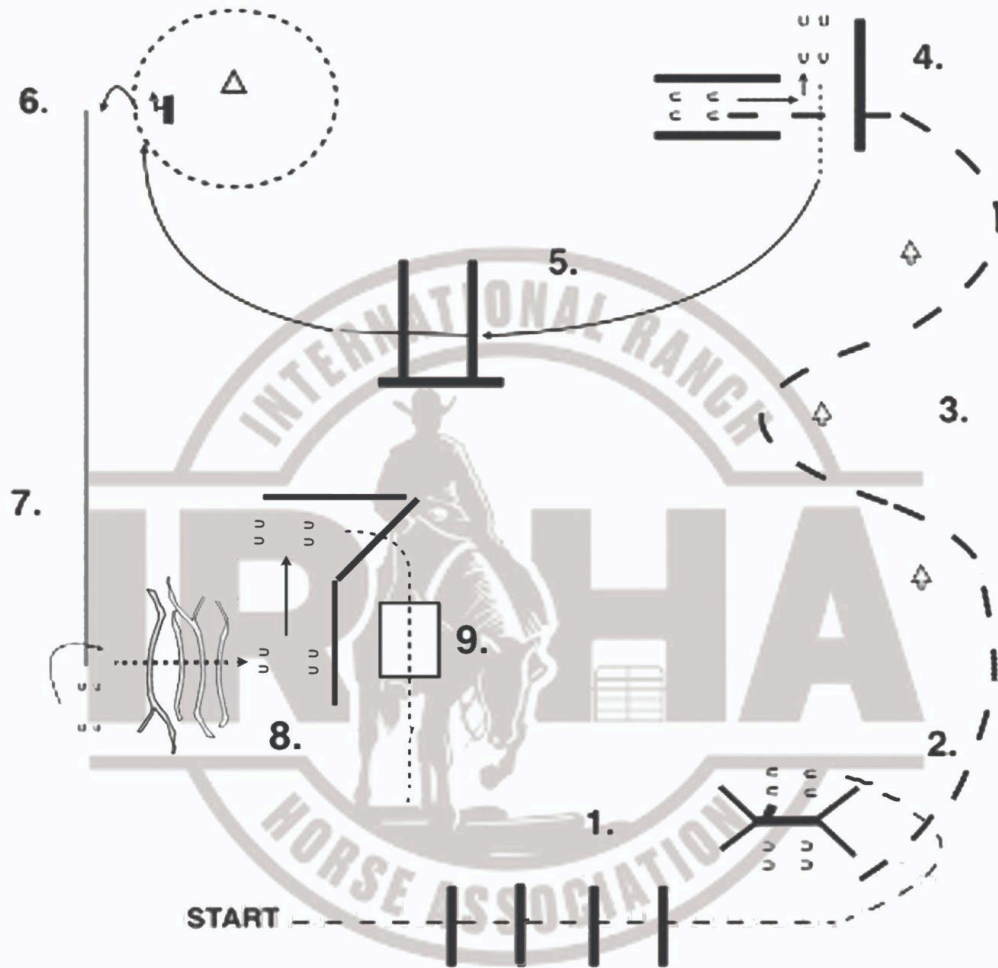

1. Trot over logs to gate.
2. Work gate
3. Extended Trot through serpentine around markers into chute.
4. Back through chute as drawn. Walk out of chute.
5. Right lead lope over logs to drag.
6. Pick up rope, then right around marker (walk or trot), replace rope.
7. Left lead lope to logs, then stop and perform a 3/4 turn to the right.
8. Walk over logs and sidepass left.
9. Walk over log and bridge. Walk to exit.



# RANCH TRAIL Open & Non Pro

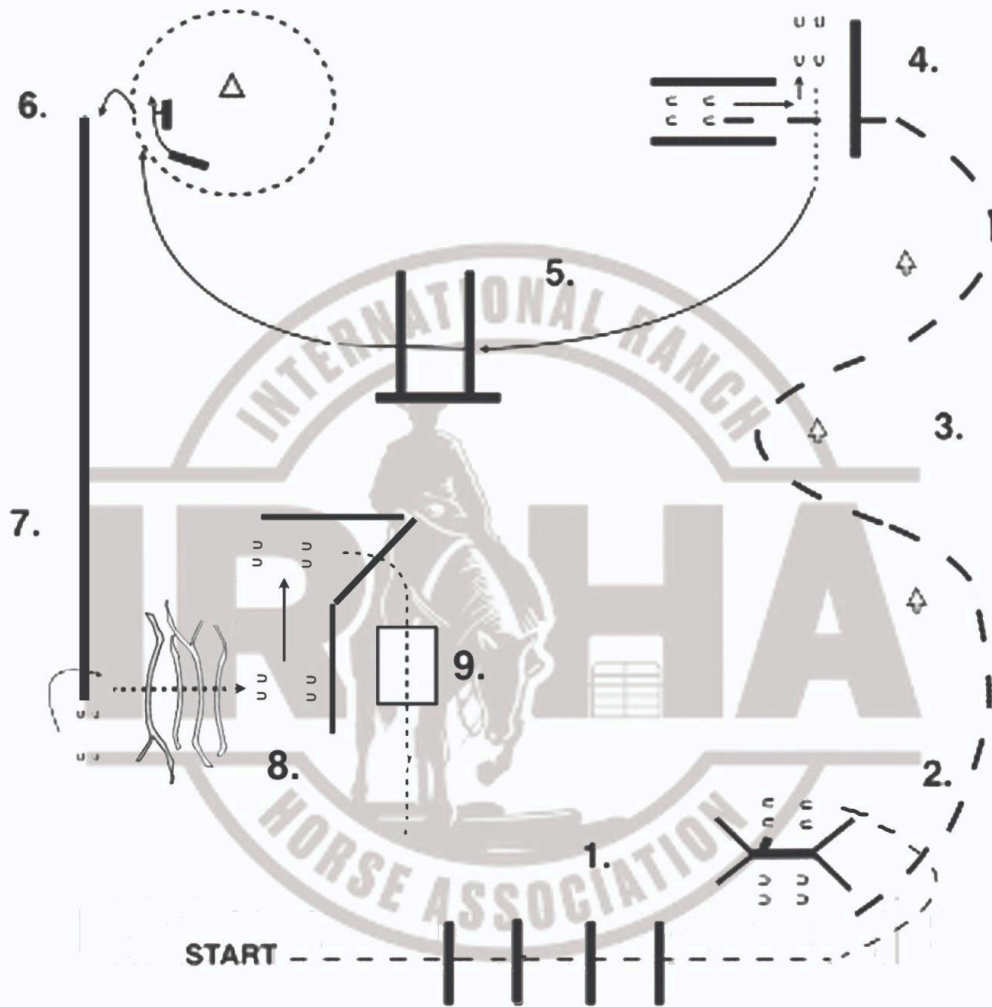

1. Trot over logs to gate.
2. Work gate
3. Extended Trot through serpentine around markers into chute.
4. Back through chute as drawn, walk out of chute.
5. Right lead lope over logs to drag.
6. Drag log to the right around marker. (walk or trot)
7. Left lead extended lope to logs, then stop and perform a 3/4 turn to the right.
8. Walk over logs and sidepass left.
9. Walk over log and bridge. Walk to exit.



# RANCH RIDING YOUTH NON PRO OPEN

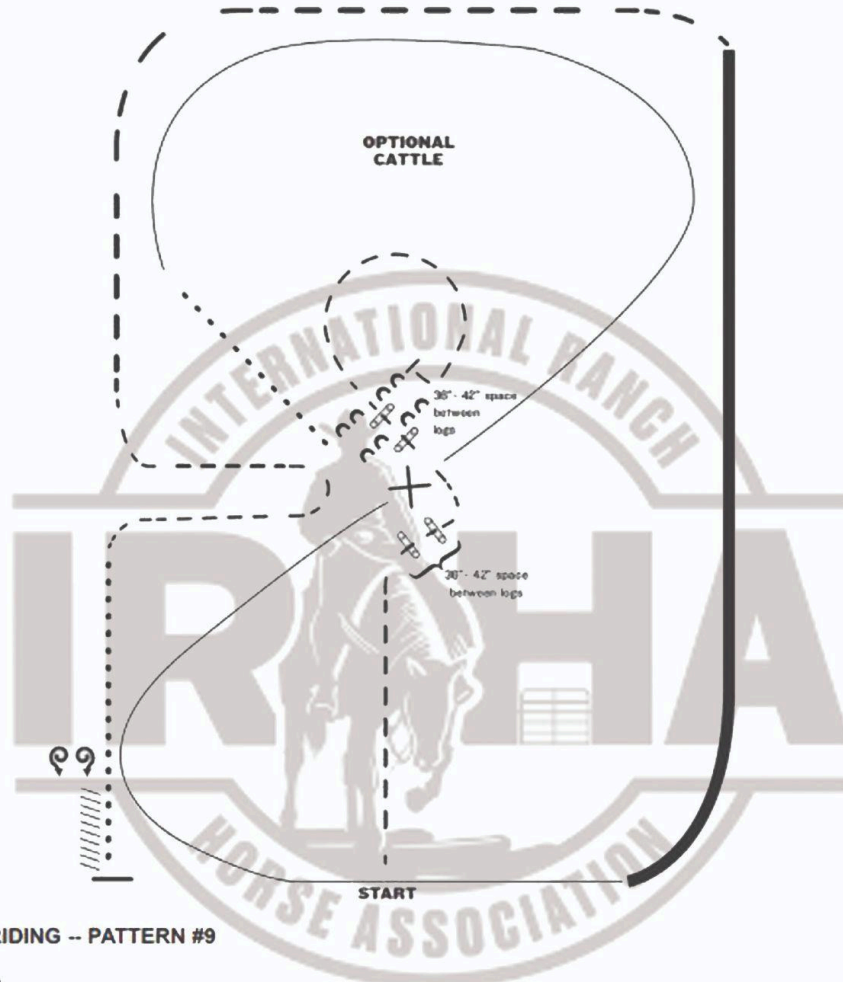

## RANCH RIDING -- PATTERN #9

1. Trot
2. Trot two sets of logs
3. Trot circle, stop and side pass log left
4. Walk
5. Lope right lead
6. Change leads (simple or flying)
7. Lope left lead
8. Extended lope (left lead)
9. Extended trot
10. Trot
11. Walk
12. Stop and back
13. 360 degree turn each direction (either direction 1st) (L-R or R-L)

## SANCTIONED EVENTS

1. \$100 Approval Fee and Show Application to IRHA 30 days prior to event
2. Results must be submitted to IRHA within two weeks after conclusion of event
3. Required 5% of entry fees to be sent to IRHA
4. Maximum 20% of entry fee to be retained by show management
5. Minimum 75% of entry fee to be added to purse
  - a. Additional added money could be generated by show management

### Payback Scale

**Payout Schedule**

# of Paid Entries	Placings Paid	1st	2nd	3rd	4th	5th	6th	7th	8th	9th	10th	11th	12th	13th	14th	15th
1-2	1	100%														
3-4	2	60%	40%													
5-6	3	45%	35%	20%												
7-9	5	34%	27%	20%	10%	9%										
10-12	6	32%	22%	19%	10%	9%	8%									
13-15	8	26%	22%	14%	10%	9%	8%	6%	5%							
16-19	10	25%	18%	13%	10%	8.5%	7%	6%	5%	4%	3.5%					
20-23	12	25%	16%	11%	9%	8%	7%	6%	5%	4%	3.5%	3%	2.5%			
24-27	14	23%	15%	10.5%	9%	8%	7%	6%	5%	4%	3.5%	3%	2.5%	2%	1.5%	
28+	15	23%	14%	10.5%	9%	8%	7%	6%	5%	4%	3.5%	3%	2.5%	2%	1.5%	1%

### Examples:

60 entries at \$100	\$6,000
20% retained by show management	\$1,200
75% to payback	\$4,500
5% to IRHA	\$300
100 entries at \$250	\$25,000
20% retained by show management	\$5,000
75% to payback	\$18,750
5% to IRHA	\$1,250